

DS-3T0510HP-E/HS 8-Port Gigabit Unmanaged Hi-PoE Switch



DS-3T0510HP-E/HS switches are layer 2 Hi-PoE switches, providing advanced PoE power supply technology and wider temperature (-30 to 65 °C) design on the basis of high-performance access to ensure stable data upload. The switches support Hi-PoE, long range, port isolation, and PoE watchdog function.

- 6 × gigabit PoE RJ45 ports, 2 × gigabit Hi-PoE RJ45 ports and 2 × gigabit SFP fiber optical ports.
- IEEE 802.3at/af/bt standard for Hi-PoE port (Max. 90 W PoE output).
- IEEE 802.3at/af standard for PoE ports (Max. 30 W PoE output).
- IEEE 802.3, IEEE 802.3u, IEEE 802.3x, IEEE 802.3z and IEEE 802.3ab standard.
- 6 KV surge protection for PoE ports.
- Up to 300 m long-range transmission.
- PoE watchdog to auto detect and restart the cameras that do not respond.
- Port isolation to improve network security.
- Wire-speed forwarding.
- Wider temperature (-30 to 65 °C) design.
- Store-and-forward switching.
- Solid high-strength metal shell.
- Reliable fan-free design.

▪ Specification

Model	DS-3T0510HP-E/HS	
Network Parameters	Ports	8 × Gigabit PoE port, 2 × Gigabit fiber optical port
	MAC Address Table	4 K
	Switching Capacity	20 Gbps
	Packet Forwarding Rate	14.88 Mpps
	Internal Cache	1.5 Mbits
PoE Power Supply	PoE Standard	IEEE 802.3af, IEEE 802.3at, IEEE 802.3bt
	PoE Power Pin	8-pin power: 1/2(-), 3/6(+), 4/5(+), 7/8(-), End-span: 1/2(-), 3/6(+)
	PoE Port	Hi-PoE: Ports 1 to 2, PoE: Ports 3 to 8
	Max. Port Power	90 W Ports 3 to 8: 30 W
	PoE Power Budget	110 W
Dialing Function	Long Range	Ports 7 to 8: up to 300 m Long range performance may vary depend on camera model or cable condition.
	Port Isolation	Ports 1 to 8: port isolation mode to improve network security.
	PoE Watchdog	Ports 1 to 8: auto detect and restart the cameras that do not respond.
General	Shell	Metal material, fan-free design
	Net Weight	0.585 kg (1.29 lb)
	Gross Weight	1.11 kg (2.45 lb)
	Dimensions (W × H × D)	197.0 mm × 114.2 mm × 42.2 mm (7.76" × 4.50" × 1.66")
	Operating Temperature	-30 °C to 65 °C (-22 °F to 149°F)
	Storage Temperature	-40 °C to 85 °C (-40 °F to 185 °F)
	Operating Humidity	5% to 95% (no condensation)
	Relative Humidity	5% to 95% (no condensation)
	Power Supply	57 VDC, 2.5 A
	Max. Power Consumption	120 W
	Power Consumption in Idle	10 W
Installation Mode	Desk-Mounted, Rail	

	Surge Protection	6 KV
Approval	EMC	FCC (47 CFR Part 15, Subpart B), CE-EMC (EN 55032: 2015+A11: 2020, EN IEC 61000-3-2: 2019, EN 61000-3-3: 2013+A1: 2019, EN 50130-4: 2011+A1: 2014, EN 55035: 2017+A11: 2020), IC (ICES-003: Issue 7:2020), RCM (AS/NZS CISPR 32: 2015)
	Safety	UL (UL 60950-1), CB (AMD1:2009, AMD2:2013, IEC 62368-1: 2014 (Second Edition), CE-LVD (EN 62368-1: 2014+A11: 2017)
	Chemistry	CE-RoHS (2011/65/EU)

▪ Typical Application

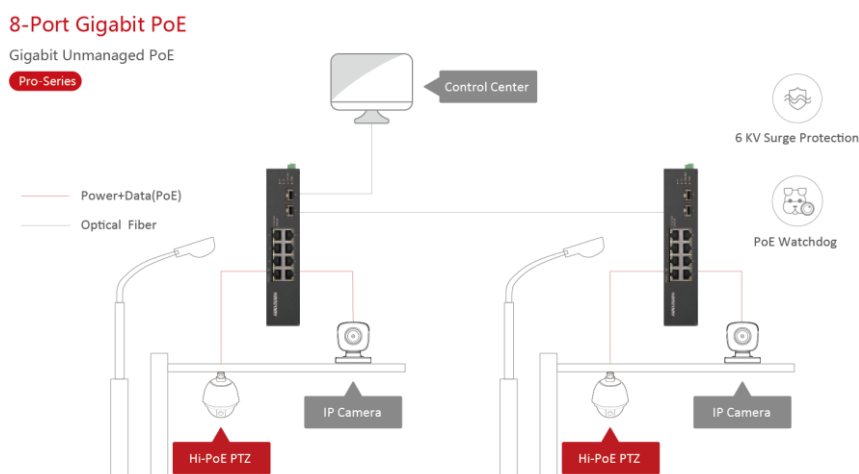

▪ Physical Interface

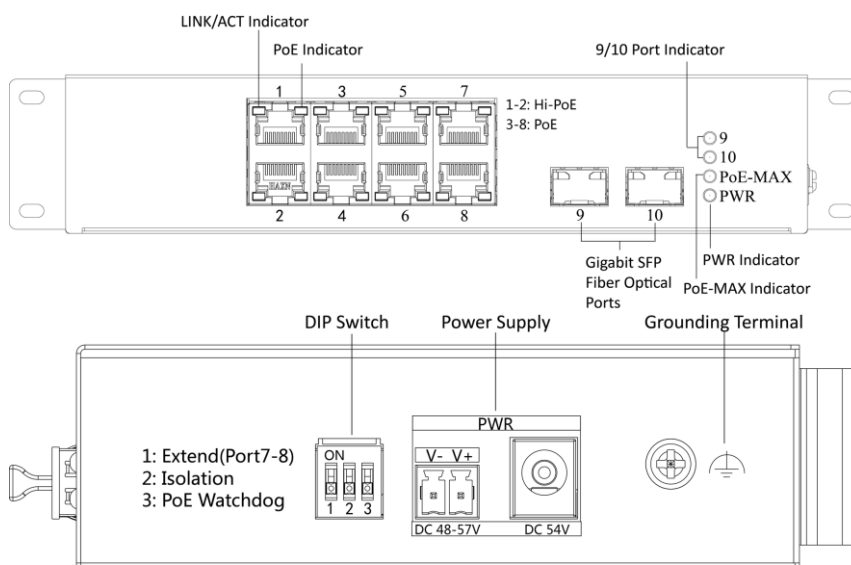

▪ Available Model

DS-3T0510HP-E/HS

DS-3T0510HP-E/HS/美分

▪ Dimension

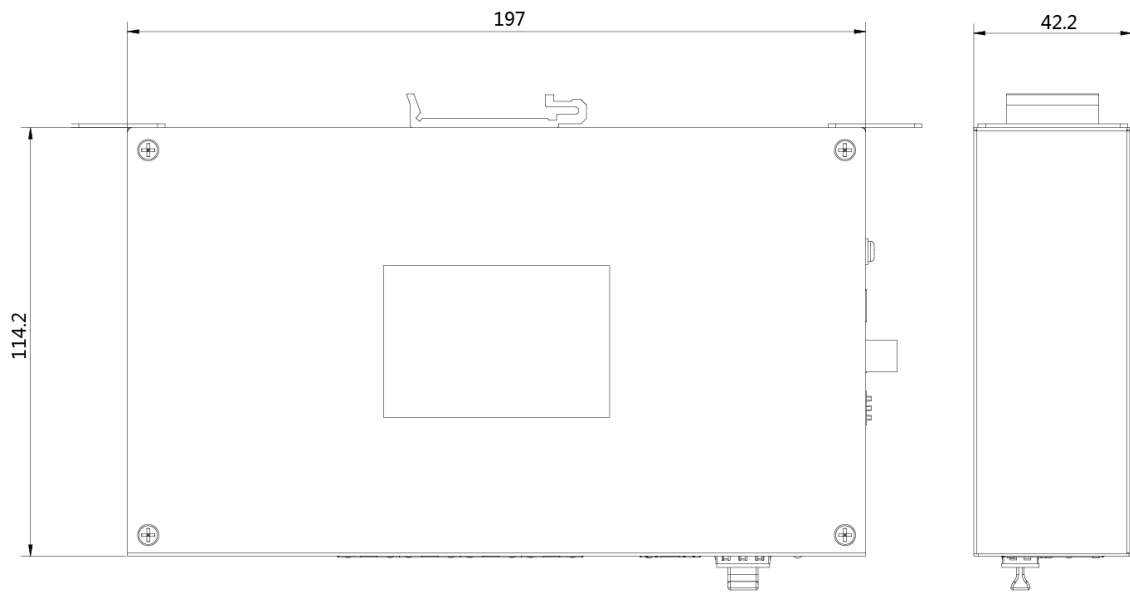

▪ **Accessory**

▪ **Optional**

HK-SFP-1.25G-20-1 550 SFP Module	HK-SFP-1.25G-20-1 310 SFP Module	HK-SFP-1.25G-1310 -DF-MM SFP Module	HK-SFP-1.25G-20-1 310-DF SFP Module	DRL-48V75W1AZ Industrial Power Supply Unit
				
DRL-48V240W1EN Industrial Power Supply Unit				

Headquarters

No.555 Qianmo Road, Binjiang District,
 Hangzhou 310051, China
 T +86-571-8807-5998
 www.hikvision.com



Follow us on social media to get the latest product and solution information.

